

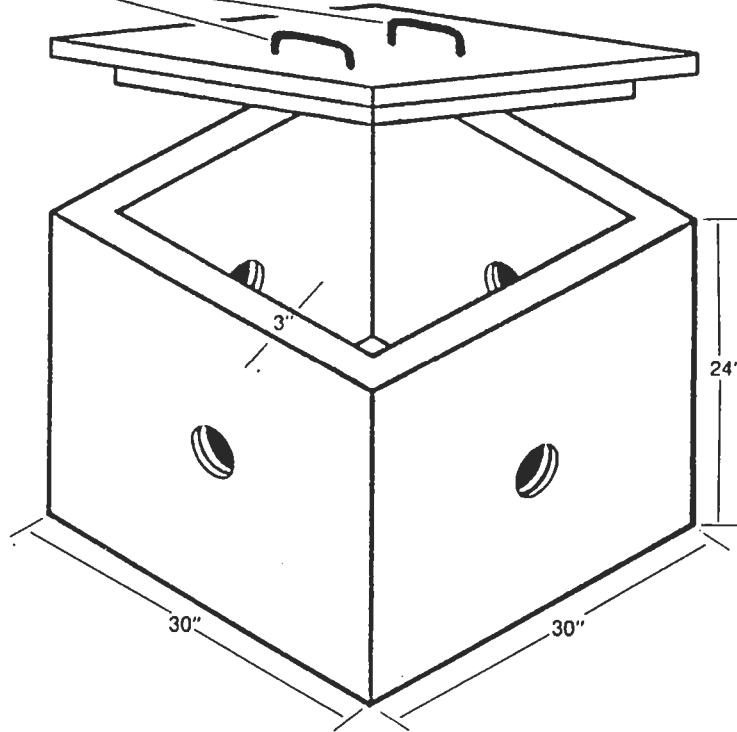

DISTRIBUTION BOX

GALVANIZED STEEL
LIFT HANDLES



DISTRIBUTION BOX
ITEM # W5•001
WEIGHT: 1005 LB.

- SPECIFICATIONS:**
- 5000 PSI at 28 days
 - Air entraining: 5-7%
 - 10 mm reinforcing as shown below
 - See detail # W8•001 on page W8•0 for detail on Polylok seal

NOTES:

- Also available without 2" floor

10 mm REINFORCING:

