

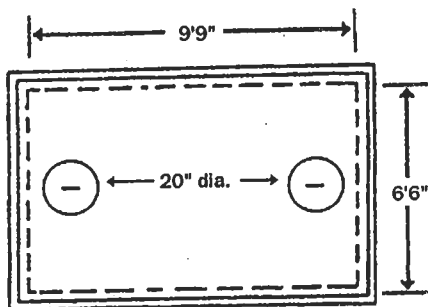

DIMENSIONS & SPECS. ON 1500 GAL. SEPTIC TANKS



TOP VIEW

ITEM # W2•401
WEIGHT: 15,800 LB.

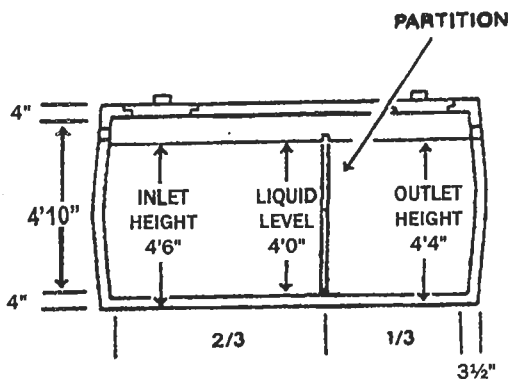

CROSS SECTION

HOLE SIZE

W	L	D
8'0"	11'0"	4'6"

* depth from bottom of inlet

- SPECIFICATIONS:**
- Approved by the P.E.I. Dept. of Fisheries, Aquaculture and Environment
 - 5000 psi at 28 days
 - Air entraining: 5-7%
 - Reinforcing as shown on page W2•3
 - See Detail # W8•001 for Polylok Seal Detail (page W8•0)

- NOTES:**
- Partition contains an 8" x 8" opening centered on liquid level
 - Partition extends 1 1/2" above liquid level