

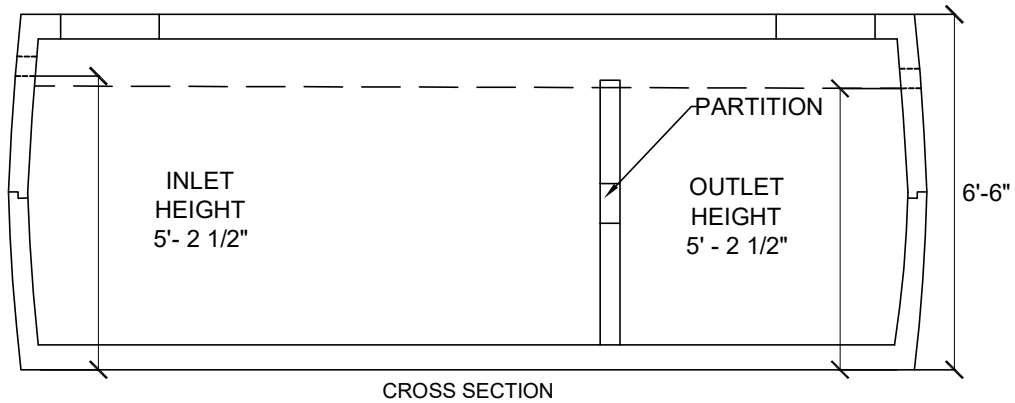

## 3000 IGAL SEPTIC TANK

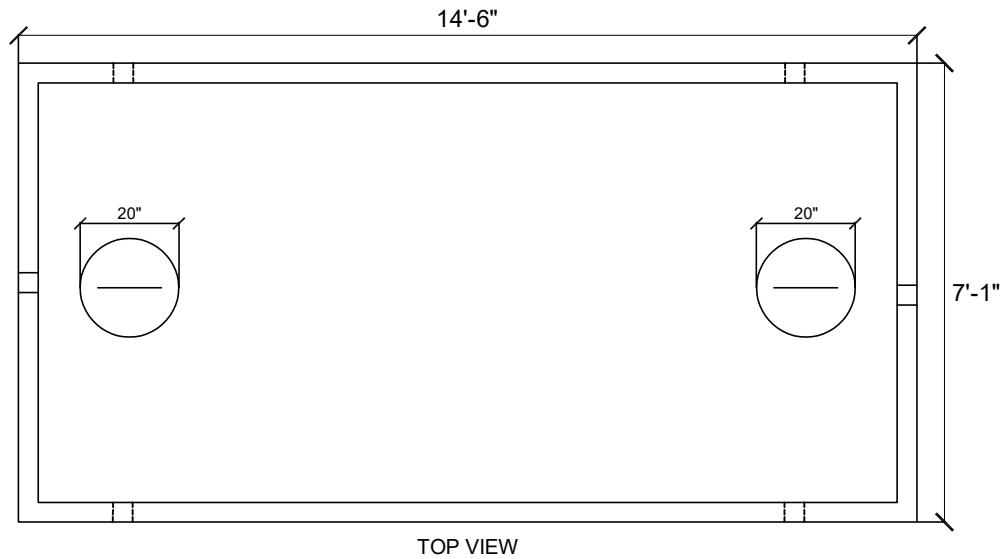

**SPECIFICATIONS:**  
 APPROVED BY PEI DEPT. OF ENVIRONMENT  
 5000 psi AT 28 DAYS  
 AIR ENTRAINING 5-7%  
 10mm REBAR REINFORCING  
 FIBRE MESH REINFORCING  
 MAXIMUM COVER IS 3 FEET

**NOTES:** - PARTITION WALL CONTAINS AN 8"X 8" OPENING CENTERED ON LIQUID LEVEL  
 -PARTITION EXTENDS 1 1/2" ABOVE LIQUID LEVEL

DESCRIPTION	ITEM #	OUTSIDE DIMENSIONS			THICKNESS			INLET	OUTLET	WEIGHT
		H	W	L	WALL	FLOOR	TOP			
3000 IGAL SEPTIC TANK	W2.601	6'-6"	7'-1"	14'-6"	4"	5"	5"	5'-4"	5'-2"	27900 LBS.