



CAMPBELL'S CONCRETE LTD.

420 MT. EDWARD ROAD, P.O. BOX 373 • CHARLOTTETOWN, P.E.I. C1A 7K7

W2.4

1500 IGAL SEPTIC TANK

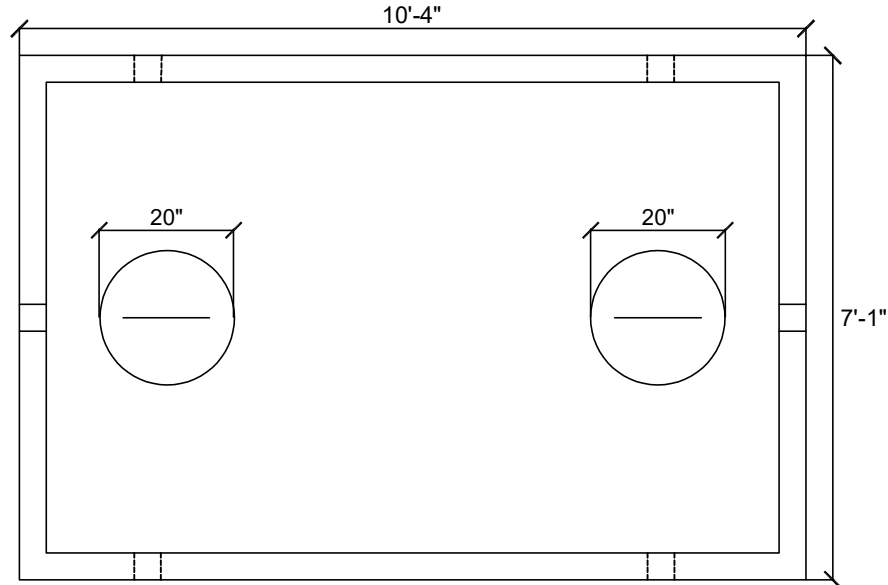

TOP VIEW

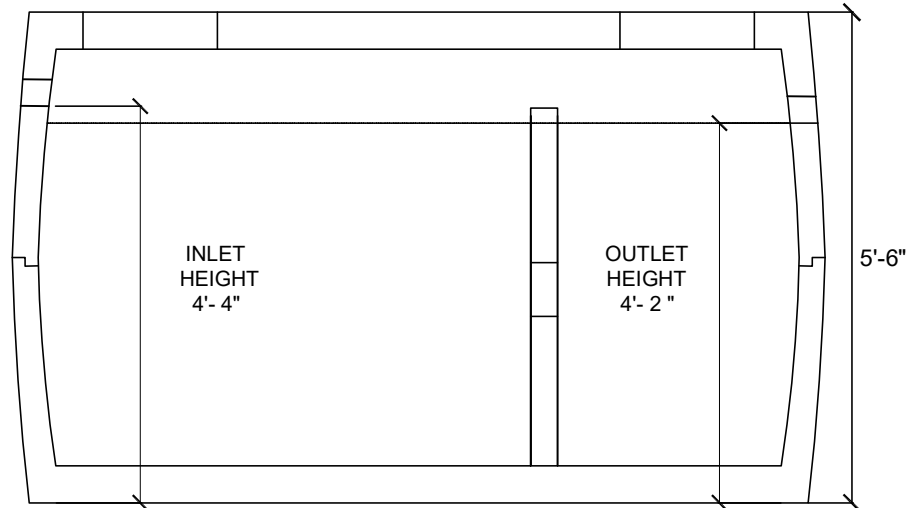

CROSS SECTION

SPECIFICATIONS:
 APPROVED BY PEI DEPT. OF ENVIRONMENT
 5000 psi AT 28 DAYS
 AIR ENTRAINING 5-7%
 10mm REBAR REINFORCING
 FIBRE MESH REINFORCING
 MAXIMUM COVER IS 5 FEET

NOTES: - PARTITION WALL CONTAINS AN 8"X 8" OPENING CENTERED ON LIQUID LEVEL
 -PARTITION EXTENDS 1 1/2" ABOVE LIQUID LEVEL

| DESCRIPTION | ITEM # | OUTSIDE DIMENSIONS | | | THICKNESS | | | INLET | OUTLET | WEIGHT |
|-----------------------|--------|--------------------|-------|--------|-----------|-------|-----|-------|--------|------------|
| | | H | W | L | WALL | FLOOR | TOP | | | |
| 1500 IGAL SEPTIC TANK | W2.401 | 5'-6" | 7'-1" | 10'-4" | 3 1/2" | 4" | 4" | 4'-6" | 4'-4" | 15800 LBS. |