

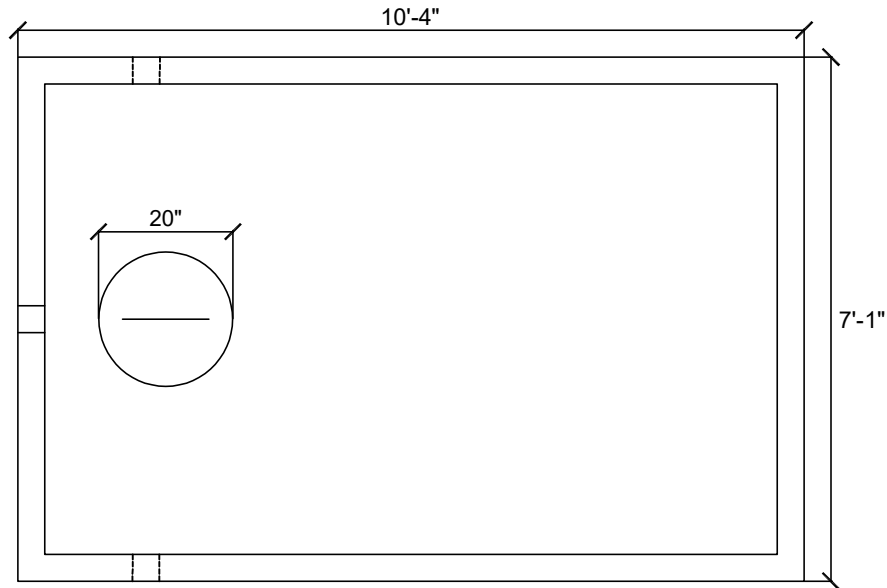

CAMPBELL'S CONCRETE LTD.
 420 MT. EDWARD ROAD, P.O. BOX 373 • CHARLOTTETOWN, P.E.I. C1A 7K7

W2.4H

1500 IGAL HOLDING TANK



TOP VIEW

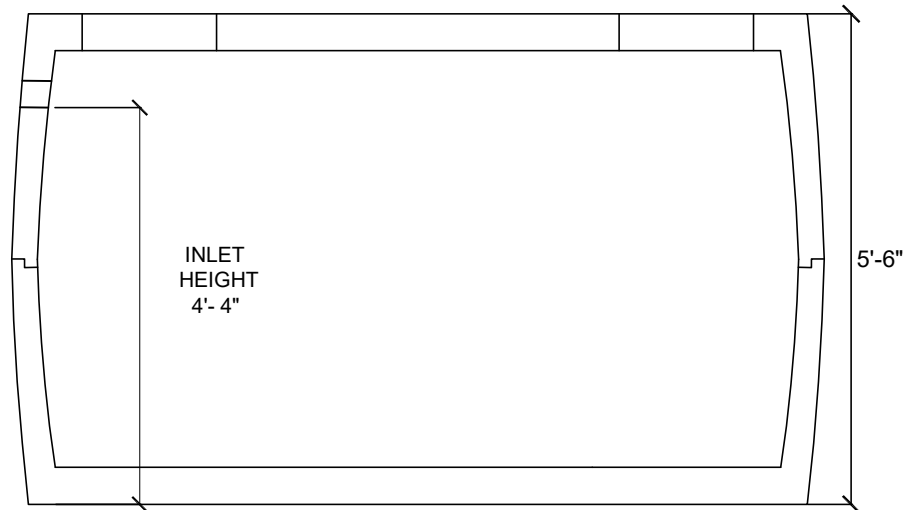

CROSS SECTION

SPECIFICATIONS:
 APPROVED BY PEI DEPT. OF ENVIRONMENT
 5000 psi AT 28 DAYS
 AIR ENTRAINING 5-7%
 10mm REBAR REINFORCING
 FIBRE MESH REINFORCING
 MAXIMUM COVER IS 5 FEET

DESCRIPTION	ITEM #	OUTSIDE DIMENSIONS			THICKNESS			INLET	OUTLET	WEIGHT
		H	W	L	WALL	FLOOR	TOP			
1500 IGAL HOLDING TANK	W2.402	5'-6"	7'-1"	10'-4"	3 1/2"	4"	4"	4'-6"	4'-4"	15800 LBS.