



CAMPBELL'S CONCRETE LTD.

420 MT. EDWARD ROAD, P.O. BOX 373 • CHARLOTTETOWN, P.E.I. C1A 7K7

W2.3

1200 IGAL SEPTIC TANK

COVER WEIGHT
3990 LBS.

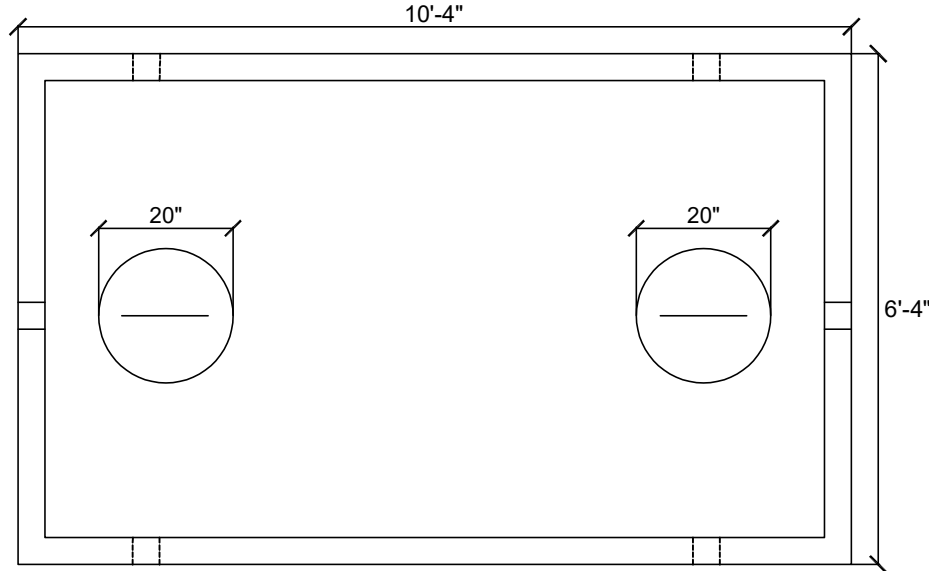

TOP VIEW

TANK WEIGHT
11960 LBS.

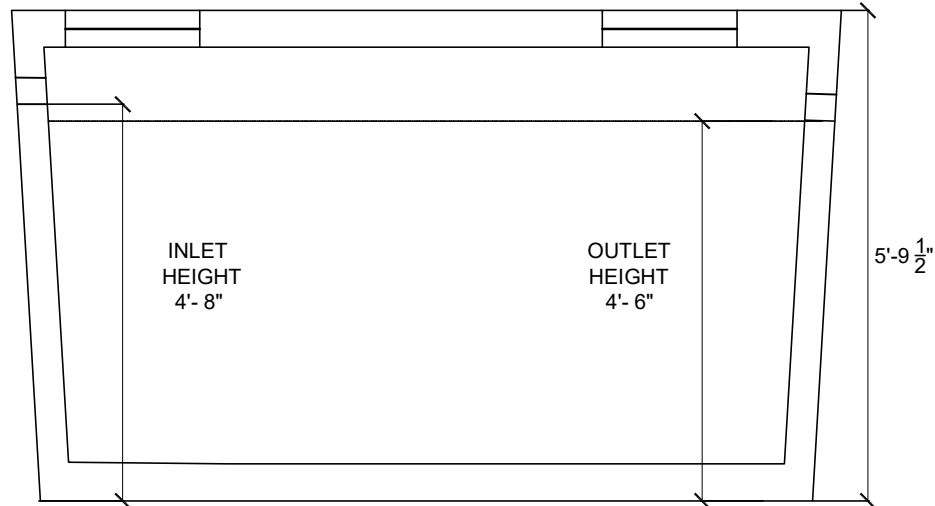

CROSS SECTION

SPECIFICATIONS:
 APPROVED BY PEI DEPT. OF ENVIRONMENT
 5000 psi AT 28 DAYS
 AIR ENTRAINING 5-7%
 10mm REBAR REINFORCING
 FIBRE MESH REINFORCING
 MAXIMUM COVER IS 5 FEET

DESCRIPTION	ITEM #	OUTSIDE DIMENSIONS			THICKNESS			INLET	OUTLET	WEIGHT
		H	W	L	WALL	FLOOR	TOP			
1200 IGAL SEPTIC TANK	W2.301	5'-9 1/2"	6'-4"	10'-4"	4 1/2"	4 1/2"	5"	4'-3"	4'-1"	15950 LBS.