

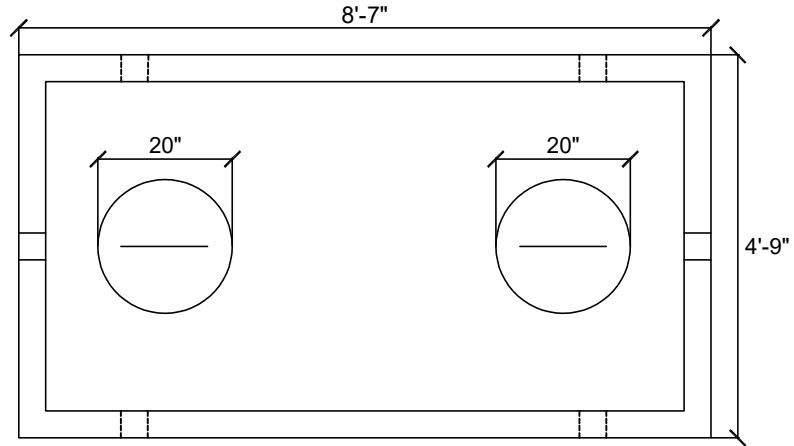

1000 IGAL SEPTIC TANK

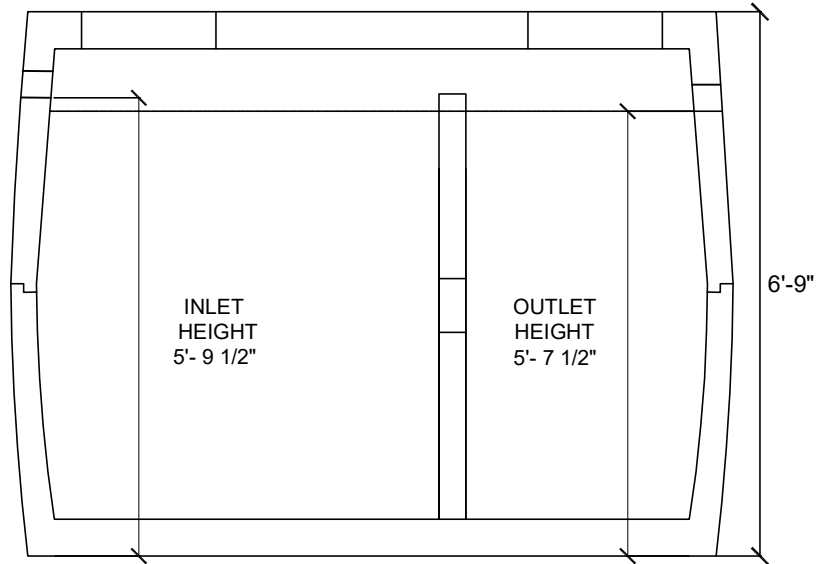

TOP VIEW



CROSS SECTION

SPECIFICATIONS:
 APPROVED BY PEI DEPT. OF ENVIRONMENT
 5000 psi AT 28 DAYS
 AIR ENTRAINING 5-7%
 10mm REBAR REINFORCING
 FIBRE MESH REINFORCING
 MAXIMUM COVER IS 5 FEET

NOTES: - PARTITION WALL CONTAINS AN 8"X 8" OPENING CENTERED ON LIQUID LEVEL
 -PARTITION EXTENDS 1 1/2" ABOVE LIQUID LEVEL

DESCRIPTION	ITEM #	OUTSIDE DIMENSIONS			THICKNESS			INLET	OUTLET	WEIGHT
		H	W	L	WALL	FLOOR	TOP			
1000 IGAL SEPTIC TANK	W2.201	6'-9"	4'-9"	8'-7"	2 1/2"	3 1/2"	3 1/2"	5'-10 1/2"	5'-8 1/2"	8350 LBS.