

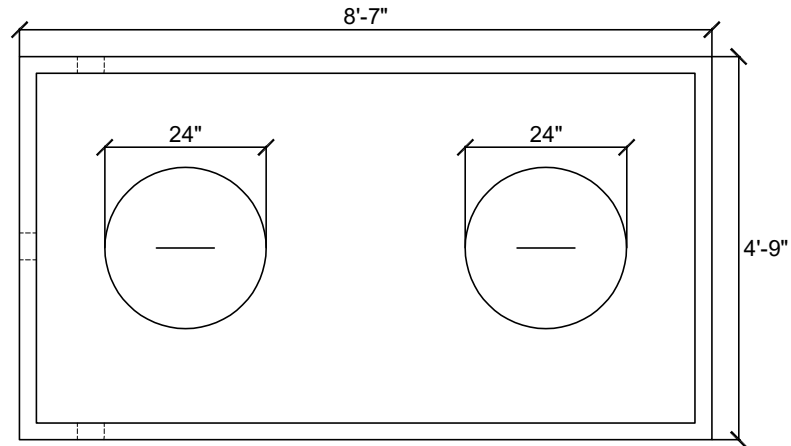

650 IGAL PUMP TANK

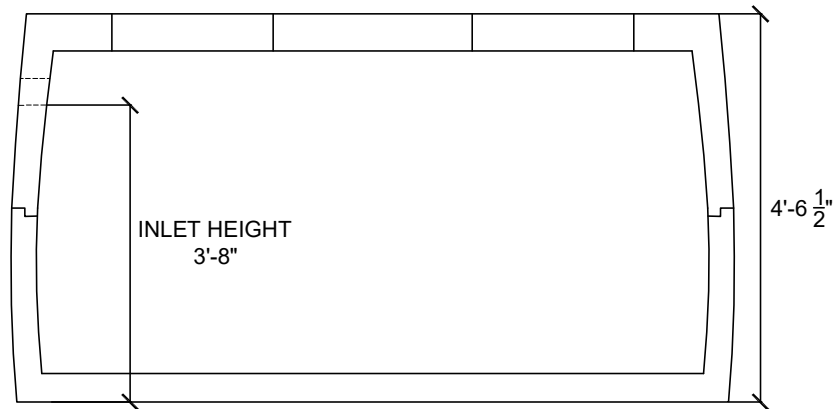

TOP VIEW



CROSS SECTION

SPECIFICATIONS:
 APPROVED BY PEI DEPT. OF ENVIRONMENT
 5000 psi AT 28 DAYS
 AIR ENTRAINING 5-7%
 10mm REBAR REINFORCING
 FIBRE MESH REINFORCING
 MAXIMUM COVER IS 5 FEET

DESCRIPTION	ITEM #	OUTSIDE DIMENSIONS			THICKNESS			INLET	WEIGHT
		H	W	L	WALL	FLOOR	TOP		
650 GAL PUMP TANK	W1.102	4'-6 1/2"	4'-9"	8'-7"	2 1/2"	3"	3 1/2"	3'-8"	6250 LBS.