

FLOWER PLANTER

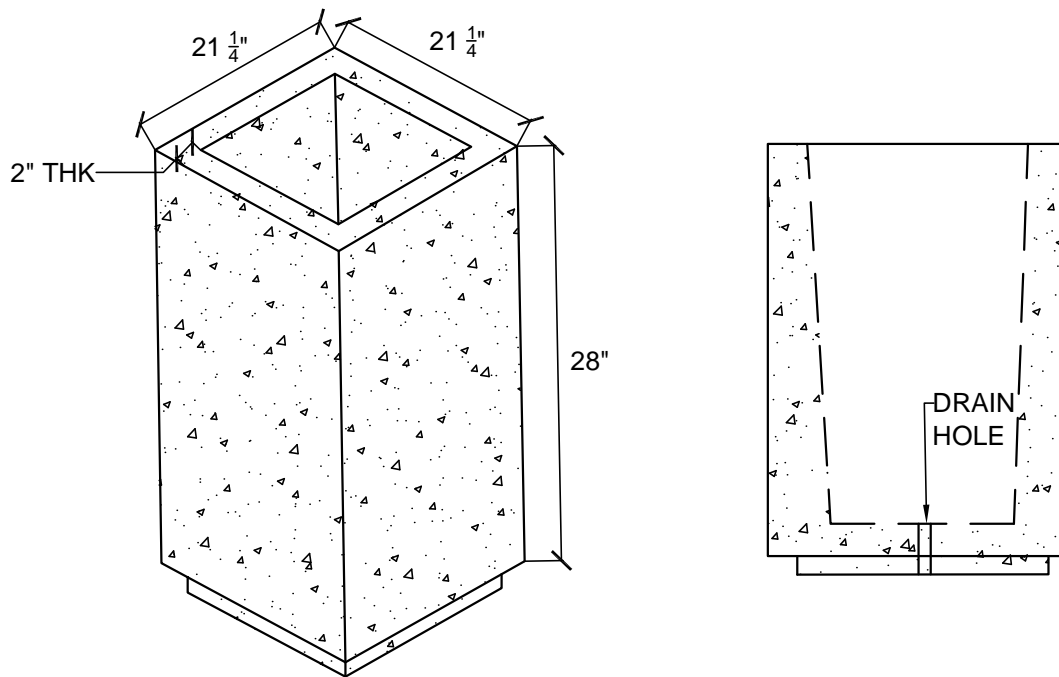

SPECIFICATIONS:
5000 psi AT 28 DAYS
AIR ENTRAINING 5-7%

ITEM # R5.001
WEIGHT 640 LB

NOTES: CONCRETE DOES NOT RUST, CORRODE OR DETERIORATE
PLANTER HAS A DRAIN HOLE TO ALLOW FOR EXCESS WATER TO PASS
A LOW MAINTENANCE SOLUTION TO DECORATIVE NEEDS
FOR ALL SEASON USE, PLANTER SHOULD BE LINED WITH STYROFOAM
TO ALLOW FOR SOIL EXPANSION